



Solar inverters

PVI-55.0/110.0, 165.0/220.0, 275.0/330.0

FIMER PVI-55.0/330.0 inverters offer the perfect solution for revamping applications. Thanks to the modular inverters allowing a wide range of configurations, based on 55 kW modular blocks, it is possible to increase the power production and improve the availability of the plant. The reduction of performance in any individual module will not impact the energy harvesting capabilities of the other modules.

From 55 to 300 kW

The product is available with and without a transformer. The industry-leading power conversion efficiency of up to 98% (for the -TL version), combined with high speed Maximum Power Point Tracking (MPPT) channels, optimize energy harvesting across a wide array of operating conditions. These inverters provide maximum DC input voltage of up to 1000 Vdc, high design flexibility and reduced DC distribution losses for large scale PV plants.

Delivered pre-configured and pretested which reduces on-site wiring and testing

The inverter systems are delivered pre-configured and pre-tested, which significantly reduces on-site wiring and testing. Except for the PVI-55.0-TL, the unit can be configured with a single or multiple MPPT. Any reduction in the performance of a single inverter does not affect the energy harvesting capacity of the other modules and of the system.

Highlights

- Reduced susceptibility to a single fault; in case of a component failure, a maximum of 55 kW will be lost
- Reduced acoustic noise due to the high switching frequency
- Integrated DC and AC distribution and protection fully equipped for connection; additional accessories not required
- Two independent RS-485 communication interfaces for the smart monitoring of the inverter and of Stringcombs
- Integrated DC disconnect switch for each 55 kW module, integrated DC and AC protection (fuses and overvoltage protection) easy to replace
- Ideal for revamping applications of MV connected PV systems: it is no longer necessary to change the MV transformer
- TL versions are now available with different AC voltage (applicable standard CEI 0-16)
- Even wider MPPT range

Block diagram of a PVI-330.0 with transformer (multi master)

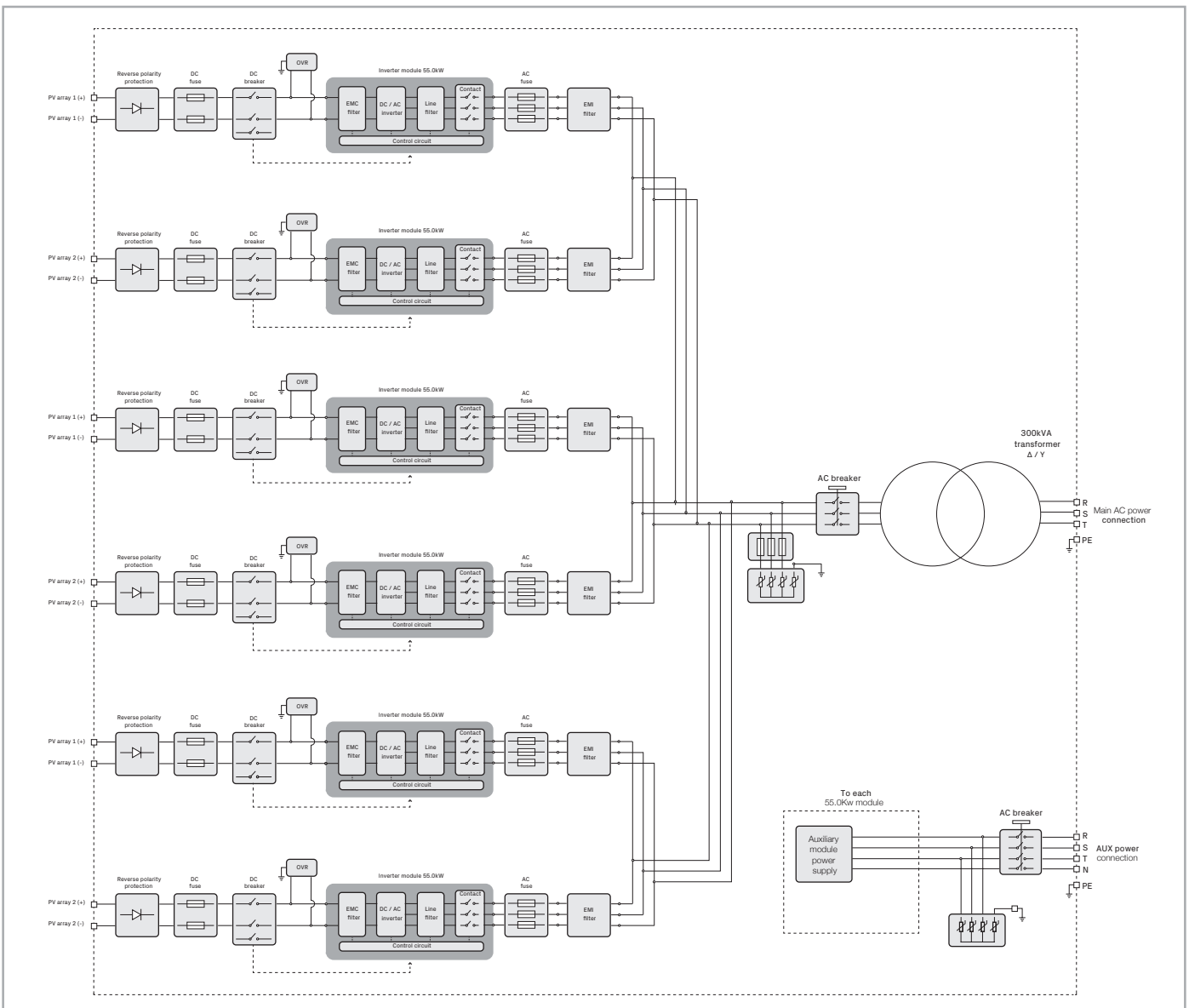

Tecnichal data and models

Model	PVI-55.0-TL	PVI-55.0-TL	PVI-110.0	PVI-110.0-TL
Input side				
Absolute maximum DC input voltage ($V_{max,abs}$)	1000 V		1000 V	
MPPT input DC voltage range ($V_{MPPTmin} \dots V_{MPPTmax}$) at V_{acr}	485...950 V		485...950 V	
MPPT input DC range ($V_{MPPTmin} \dots V_{MPPTmax}$) at P_{acr} and V_{acr}	Linear derating from max to 31.8% [800< V_{MPPT} <950V]		Linear derating from max to 31.8% [800< V_{MPPT} <950V]	
Number of independent MPPT multi-master	1		2	
Number of independent MPPT multi-master/slave	Not applicable		Not applicable	
Number of independent MPPT master/slave	1		1	
Maximum combined DC input current ($I_{dc,max,c}$)	123 A		246 A	
Maximum DC input current for each module ($I_{dc,max,m}$)	123 A		123 A	
Number of DC inputs pairs	1		2	
DC connection type	2x185mm ² (M10)		2x185mm ² (M10) + 2x300mm ² (M10)	
Input protection				
Reverse polarity protection	Yes, with series diode		Yes, with series diode	
Input overvoltage protection - varistor	1 for each input pair, Class II		1 for each input pair, Class II	
Photovoltaic array leakage control, floating neutral, floating panels	No; proprietary control available ³⁾		No; proprietary control available ³⁾	
Residual current protection, grounded neutral, floating panels	Not included; dimension output ground fault device with $\Delta I=400mA/module$		Not included; dimension output ground fault device with $\Delta I=400mA/module$	
Fuse size for each input pair	125 A / 1000 V		125 A / 1000 V	
Output side				
AC grid connection type	Three phases 4W+PE	Three phases 3W+PE	Three phases 4W+PE	Three phases 3W+PE
Rated AC power ($P_{acr} @ \cos\phi=1$)	55 kW		110 kW	
Maximum AC output power ($P_{ac,max} @ \cos\phi=1$)	55 kW		110 kW	
Maximum apparent power (S_{max})	61 kVA		122kVA	
Rated grid voltage (V_{acr})	400 V	320 V	400V	320 V
AC voltage range ($V_{ac,min} \dots V_{ac,max}$)	320...480 V ¹⁾	256...368 V ¹⁾	320...480 V ¹⁾	256...368 V ¹⁾
Maximum output current ($I_{ac,max}$)	81 A	101 A	160 A	202 A
Contributory fault current	90 A	112.5 A	180 A	225 A
Rated frequency (f _r)	50/60 Hz		50/60 Hz	
Frequency range (f _{min} ...f _{max})	47...53 / 57...63 Hz ²⁾		47...53 / 57...63 Hz ²⁾	
Nominal power factor and adjustable range	> 0.995 (adj. \pm 0.90)		> 0.995 (adj. \pm 0.90)	
Total harmonic distortion	< 3% (@ P_{acr})		< 3% (@ P_{acr})	
AC connection type (for each phase)	1 x 95 mm ² (M8)	1 x 300 mm ² (M12)	1 x 95 mm ² (M8)	1 x 300 mm ² (M12)
Output protection				
Anti-islanding protection	According to local standard		According to local standard	
Output overvoltage protection (varistor)	Yes, Class II		Yes, Class II	
Night time disconnect	Yes	No	Yes	No
AC circuit breaker	50 kA		50 kA	
Operating performance				
Maximum efficiency (η_{max})	96.3% ⁴⁾	98.0% ⁴⁾	96.4% ⁴⁾	98.0% ⁴⁾
Weighted efficiency (η_{EURO} / η_{DEC})	95.1% / 96.0% ⁴⁾	97.7% / 97.5% ⁴⁾	95.2% / 96.0% ⁴⁾	97.7% / 97.5% ⁴⁾
Stand-by consumption/night-time power loss	< 17 W	< 23 W	< 24 W	< 19 W
AC auxiliary supply	3x400 Vac +N, 50/60 Hz		3 x 400 Vac +N, 50/60 Hz	
Auxiliary supply consumption	< 0.36% of P_{acr}	< 0.24% of P_{acr}	< 0.31% of P_{acr}	< 0.24% of P_{acr}
Auxiliary supply consumption without cooling	< 0.25% of P_{acr}	< 0.22% of P_{acr}	< 0.23% of P_{acr}	< 0.22% of P_{acr}
Inverter switching frequency	18 kHz		18 kHz	
Communication				
Wired local monitoring	PVI-USB-RS232_485 (opt.)		PVI-USB-RS232_485 (opt.)	
Remote monitoring	PVI-AEC-EVO (opt.), VSN700 Data Logger (opt.)		PVI-AEC-EVO (opt.), VSN700 Data Logger (opt.)	
String Combiner	PVI-STRINGCOMB (opt.)		PVI-STRINGCOMB (opt.)	
User interface	16 characters x 2 line LCD display for each module		16 characters x 2 line LCD display for each module	
Environmental				
Ambient temperature range	-10...+60°C/+14...140°F with derating above 50°C/122°F		-10...+60°C/+14...140°F with derating above 50°C/122°F	
Relative humidity	0...95% non condensing		0...95% non condensing	
Noise emission	<62 dB(A) @ 1 m	<62 dB(A) @ 1 m	<65 dB(A) @ 1 m	< 63 db (A) @ 1 m
Maximum operating altitude without derating	1000 m / 3280 ft		1000 m / 3280 ft	
Physical				
Environmental protection rating	IP 20		IP 20	
Cooling	Air forced		Air forced	
Required air cooling flow	1600 m ³ /h - 944 CFM	1600 m ³ /h - 944 CFM	2800 m ³ /h - 1652 CFM	2400 m ³ /h - 1416 CFM
Dimension (H x W x D)	1675mm x 1250mm x 850mm / 69.5" x 49.2" x 33.5"	1077mm x 1250mm x 850mm / 42.4" x 49.2" x 33.5"	1675mm x 1250mm x 850mm / 65.9" x 49.2" x 33.5"	1077mm x 1250mm x 850mm / 42.4" x 49.2" x 33.5"
Weight	< 700 kg / 1543 lb	< 350 kg / 771 lb	< 800 kg / 1765 lb	< 480 kg / 1058 lb
Weight of the module	< 60 kg / 132 lb		< 60 kg / 132 lb	
Safety				
Transformer	Yes	No	Yes	No
Marking	CE (50 Hz only)		CE (50 Hz only)	
Safety and EMC standard	EN 50178, EN61000-6-2, EN61000-6-4, EN61000-3-11, EN61000-3-12		EN 50178, EN61000-6-2, EN61000-6-4, EN61000-3-11, EN61000-3-12	
Grid standard	CEI 0-21, CEI 0-16, BDEW, RD 661/2007, RD 1565/2010, P.O.12.3	CEI-0-16, BDEW, RD 661/2007, RD 1565/2010, P.O.12.3	CEI 0-21, CEI 0-16, BDEW, RD 661/2007, RD 1565/2010, P.O.12.3	CEI-0-16, BDEW, RD 661/2007, RD 1565/2010, P.O.12.3
(check your sales channel for availability)	1565/2010, P.O.12.3		1565/2010, P.O.12.3	

¹⁾ The AC voltage range may vary depending on specific country grid standard

²⁾ The Frequency range may vary depending on specific country grid standard

³⁾ Missing symmetry with respect to ground results in AC disconnection (disabled function by default)

⁴⁾ Power consumption of the auxiliary services not included

Remark. Features not specifically listed in the present data sheet are not included in the product

Tecnichal data and models

Type code	PVI-165.0	PVI-165.0-TL	PVI-220.0	PVI-220.0-TL
Input side				
Absolute maximum DC input voltage ($V_{max,abs}$)	1000 V		1000 V	
MPPT input DC voltage range ($V_{MPPTmin} \dots V_{MPPTmax}$) at V_{acr}	485...950 V		485...950 V	
MPPT input DC range ($V_{MPPTmin} \dots V_{MPPTmax}$) at P_{acr} and V_{acr}	Linear derating from max to 31.8% [800< V_{MPPT} <950V]		Linear derating from max to 31.8% [800< V_{MPPT} <950V]	
Number of independent MPPT multi-master	3		4	
Number of independent MPPT multi-master/slave	2		2	
Number of independent MPPT master/slave	1		1	
Maximum combined DC input current ($I_{dc,max,c}$)	369 A		492 A	
Maximum DC input current for each module ($I_{dc,max,m}$)	123 A		123 A	
Number of DC inputs pairs	3		4	
DC connection type	4x185mm ² (M10) + 2x300mm ² (M10)		4x185mm ² (M10)+ 4x300mm ² (M10)	
Input protection				
Reverse polarity protection	Yes, with series diode		Yes, with series diode	
Input overvoltage protection - varistor	1 for each input pair, Class II		1 for each input pair, Class II	
Photovoltaic array leakage control, floating neutral, floating panels	No; proprietary control available ³⁾		No; proprietary control available ³⁾	
Residual current protection, grounded neutral, floating panels	Not included; dimension output ground fault device with $\Delta I=400mA/module$		Not included; dimension output ground fault device with $\Delta I=400mA/module$	
Fuse size for each input pair	125 A / 1000 V		125 A / 1000 V	
Output side				
AC grid connection type	Three phases 4W+PE	Three phases 3W+PE	Three phases 4W+PE	Three phases 3W+PE
Rated AC power ($P_{acr} @ \cos\phi=1$)	165 kW		220 kW	
Maximum AC output power ($P_{ac,max} @ \cos\phi=1$)	165 kW		220 kW	
Maximum apparent power (S_{max})	183 kVA		244 kVA	
Rated grid voltage (V_{acr})	400 V	320 V	400 V	320 V
AC voltage range ($V_{ac,min} \dots V_{ac,max}$)	320...480 V ¹⁾	256...368 V ¹⁾	320...480 V ¹⁾	256...368 V ¹⁾
Maximum output current ($I_{ac,max}$)	240 A	303 A	320 A	404 A
Contributory fault current	270 A	337.5 A	360 A	450 A
Rated frequency (f)	50/60 Hz		50/60 Hz	
Frequency range ($f_{min} \dots f_{max}$)	47...53 / 57...63 Hz ²⁾		47...53 / 57...63 Hz ²⁾	
Nominal power factor and adjustable range	> 0.995 (adj. \pm 0.90)		> 0.995 (adj. \pm 0.90)	
Total harmonic distortion	< 3% (@ P_{acr})		< 3% (@ P_{acr})	
AC connection type (for each phase)	1 x 185 mm ² (M10)	2 x 300 mm ² (M12)	1 x 185 mm ² (M10)	2 x 300 mm ² (M12)
Output protection				
Anti-islanding protection	According to local standard		According to local standard	
Output overvoltage protection (varistor)	Yes, Class II		Yes, Class II	
Night time disconnect	Yes	No	Yes	No
AC circuit breaker	50 kA		50 kA	
Operating performance				
Maximum efficiency (η_{max})	96.5% ⁴⁾	98.0% ⁴⁾	96.5% ⁴⁾	98.0% ⁴⁾
Weighted efficiency (η_{EURO} / η_{CEC})	95.3% / 96.0% ⁴⁾	97.7% / 97.5% ⁴⁾	95.3% / 96.0% ⁴⁾	97.7% / 97.5% ⁴⁾
Stand-by consumption/night-time power loss	< 26 W		< 28 W	
AC auxiliary supply	3 x 400 Vac +N, 50/60 Hz		3 x 400 Vac +N, 50/60 Hz	
Auxiliary supply consumption	< 0.30% of P_{acr}	< 0.24% of P_{acr}	< 0.28% of P_{acr}	< 0.24% of P_{acr}
Auxiliary supply consumption without cooling	< 0.23% of P_{acr}	< 0.22% of P_{acr}	< 0.22% of P_{acr}	< 0.22% of P_{acr}
Inverter switching frequency	18 kHz		18 kHz	
Communication				
Wired local monitoring	PVI-USB-RS232_485 (opt.)		PVI-USB-RS232_485 (opt.)	
Remote monitoring	PVI-AEC-EVO (opt.), VSN700 Data Logger (opt.)		PVI-AEC-EVO (opt.), VSN700 Data Logger (opt.)	
String Combiner	PVI-STRINGCOMB (opt.)		PVI-STRINGCOMB (opt.)	
User interface	16 characters x 2 line LCD display for each module		16 characters x 2 line LCD display for each module	
Environmental				
Ambient temperature range	-10...+60°C/+14...140°F with derating above 50°C/122°F		-10...+60°C/+14...140°F with derating above 50°C/122°F	
Relative humidity	0...95% non condensing		0...95% non condensing	
Noise emission	< 68 db (A) @ 1 m	< 66 db (A) @ 1 m	< 72 db (A) @ 1 m	< 69 db (A) @ 1 m
Maximum operating altitude without derating	1000 m / 3280 ft		1000 m / 3280 ft	
Physical				
Environmental protection rating	IP 20		IP 20	
Cooling	Air forced		Air forced	
Required air cooling flow	4000 m ³ /h - 2360 CFM	3200 m ³ /h - 1888 CFM	4800 m ³ /h - 2832 CFM	4000 m ³ /h - 2360 CFM
Dimension (H x W x D)	2184mm x 1250mm x 850mm / 86.0" x 49.2" x 33.5"	1675mm x 1250mm x 850mm / 65.9" x 49.2" x 33.5"	2184mm x 1250mm x 850mm / 86.0" x 49.2" x 33.5"	1675mm x 1250mm x 850mm / 65.9" x 49.2" x 33.5"
Weight	< 1200 kg / 2646 lb	< 680 kg / 1500 lb	< 1300 kg / 2867 lb	< 780 kg / 1720 lb
Weight of the module	< 60 kg / 132 lb		< 60 kg / 132 lb	
Safety				
Transformer	Yes	No	Yes	No
Marking	CE (50 Hz only)		CE (50 Hz only)	
Safety and EMC standard	EN 50178, EN61000-6-2, EN61000-6-4, EN61000-3-11, EN61000-3-12		EN 50178, EN61000-6-2, EN61000-6-4, EN61000-3-11, EN61000-3-12	
Grid standard (check your sales channel for availability)	CEI 0-21, CEI 0-16, BDEW, RD 661/2007, RD 1565/2010, P.O.12.3	CEI 0-16, BDEW, RD 661/2007, RD 1565/2010, P.O.12.3	CEI 0-16, BDEW, RD 661/2007, RD 1565/2010, P.O.12.3	CEI 0-16, BDEW, RD 661/2007, RD 1565/2010, P.O.12.3

¹⁾ The AC voltage range may vary depending on specific country grid standard

²⁾ The Frequency range may vary depending on specific country grid standard

³⁾ Missing symmetry with respect to ground results in AC disconnection (disabled function by default)

⁴⁾ Power consumption of the auxiliary services not included

Remark. Features not specifically listed in the present data sheet are not included in the product

Tecnichal data and models

Type code	PVI-275.0	PVI-275.0-TL	PVI-330.0	PVI-330.0-TL
Input side				
Absolute maximum DC input voltage ($V_{max,abs}$)	1000 V		1000 V	
MPPT input DC voltage range ($V_{MPPTmin} \dots V_{MPPTmax}$) at V_{acr}	485...950 V		485...950 V	
MPPT input DC range ($V_{MPPTmin} \dots V_{MPPTmax}$) at P_{acr} and V_{acr}	Linear derating from max to 31.8% [800< V_{MPPT} <950V]		Linear derating from max to 31.8% [800< V_{MPPT} <950V]	
Number of independent MPPT multi-master	5		6	
Number of independent MPPT multi-master/slave	3		3	
Number of independent MPPT master/slave	1		1	
Maximum combined DC input current ($I_{ac,max,c}$)	615 A		738 A	
Maximum DC input current for each module ($I_{dc,max,m}$)	123 A		123 A	
Number of DC inputs pairs	5		6	
DC connection type	6x185mm ² (M10) +4x300mm ² (M10)		6x185mm ² (M10) +6x300mm ² (M10)	
Input protection				
Reverse polarity protection	Yes, with series diode		Yes, with series diode	
Input overvoltage protection - varistor	1 for each input pair, Class II		1 for each input pair, Class II	
Photovoltaic array leakage control, floating neutral, floating panels	No; proprietary control available ³⁾		No; proprietary control available ³⁾	
Residual current protection, grounded neutral, floating panels	Not included; dimension output ground fault device with $\Delta I=400mA/module$		Not included; dimension output ground fault device with $\Delta I=400mA/module$	
Fuse size for each input pair	125 A / 1000 V		125 A / 1000 V	
Output side				
AC grid connection type	Three phases 4W+PE		Three phases 3W+PE	
Rated AC power ($P_{acr} @ \cos\phi=1$)	275 kW	275 kW	330 kW	330 kW
Maximum AC output power ($P_{ac,max} @ \cos\phi=1$)	275 kW	275 kW	330 kW	330 kW
Maximum apparent power (S_{max})	305 kVA	305 kVA	366 kVA	366 kVA
Rated grid voltage (V_{acr})	400 V	320 V	400 V	320 V
AC voltage range ($V_{ac,min} \dots V_{ac,max}$)	320...480 V ¹⁾	256...368 V ¹⁾	320...480 V ¹⁾	256...368 V ¹⁾
Maximum output current ($I_{ac,max}$)	400 A	505 A	480 A	606 A
Contributory fault current	450 A	562.5 A	540 A	675 A
Rated frequency (f_r)	50/60 Hz		50/60 Hz	
Frequency range ($f_{min} \dots f_{max}$)	47...53 / 57...63 Hz ²⁾		47...53 / 57...63 Hz ²⁾	
Nominal power factor and adjustable range	> 0.995 (adj. \pm 0.90)		> 0.995 (adj. \pm 0.90)	
Total harmonic distortion	< 3% (@ P_{acr})		< 3% (@ P_{acr})	
AC connection type (for each phase)	1 x 240 mm ² (M12)	2 x 300 mm ² (M12)	1 x 240 mm ² (M12)	2 x 300 mm ² (M12)
Output protection				
Anti-islanding protection	According to local standard		According to local standard	
Output overvoltage protection (varistor)	Yes, Class II		Yes, Class II	
Night time disconnect	Yes	No	Yes	No
AC circuit breaker	50 kA		50 kA	
Operating performance				
Maximum efficiency (η_{max})	96.7% ⁴⁾	98.0% ⁴⁾	96.7% ⁴⁾	98.0% ⁴⁾
Weighted efficiency (η_{EURO} / η_{DEC})	95.5% / 96.0% ⁴⁾	97.7% / 97.5% ⁴⁾	95.5% / 96.0% ⁴⁾	97.7% / 97.5% ⁴⁾
Stand-by consumption/night-time power loss	< 45 W		< 47 W	
AC auxiliary supply	3 x 400 Vac +N, 50/60 Hz		3 x 400 Vac +N, 50/60 Hz	
Auxiliary supply consumption	< 0.29% of $P_{ac,f}$	< 0.24% of $P_{ac,f}$	< 0.28% of $P_{ac,f}$	< 0.24% of $P_{ac,f}$
Auxiliary supply consumption without cooling	< 0.22% of $P_{ac,f}$	< 0.22% of $P_{ac,f}$	< 0.22% of $P_{ac,f}$	< 0.22% of $P_{ac,f}$
Inverter switching frequency	18 kHz		18 kHz	
Communication				
Wired local monitoring	PVI-USB-RS232_485 (opt.)		PVI-USB-RS232_485 (opt.)	
Remote monitoring	PVI-AEC-EVO (opt.), VSN700 Data Logger (opt.)		PVI-AEC-EVO (opt.), VSN700 Data Logger (opt.)	
String Combiner	PVI-STRINGCOMB (opt.)		PVI-STRINGCOMB (opt.)	
User interface	16 characters x 2 line LCD display for each module		16 characters x 2 line LCD display for each module	
Environmental				
Ambient temperature range	-10...+60°C/+14...140°F with derating above 50°C/122°F		-10...+60°C/+14...140°F with derating above 50°C/122°F	
Relative humidity	0...95% non condensing		0...95% non condensing	
Noise emission	< 75 db (A) @ 1 m	< 72 db (A) @ 1 m	< 78 db (A) @ 1 m	< 75 db (A) @ 1 m
Maximum operating altitude without derating	1000 m / 3280 ft		1000 m / 3280 ft	
Physical				
Environmental protection rating	IP 20		IP 20	
Cooling	Air forced		Air forced	
Required air cooling flow	6800 m ³ /h - 4012 CFM 2184mm x 1250mm x 850mm / 86.0" x 49.2" x	4800 m ³ /h - 2832 CFM 2184mm x 1250mm x 850mm / 86.0" x 49.2" x	7600 m ³ /h - 4484 CFM 2184mm x 1250mm x 850mm / 86.0" x 49.2" x	5600 m ³ /h - 3304 CFM 2184mm x 1250mm x 850mm / 86.0" x 49.2" x
Dimension (H x W x D)	33.5", 1215mm x 1250mm x 870mm / 47.8" x 49.2" x 34.3" (Transf.)	33.5"	33.5", 1215 mm x 1250mm x 870mm / 47.8" x 49.2" x 34.3" (Transf.)	33.5"
Weight	< 1600 kg / 3527 lb	< 1000 kg / 2205 lb	< 1750 kg / 3858 lb	< 1150 kg / 2535 lb
Weight of the module	< 60 kg / 132 lb		< 60 kg / 132 lb	
Safety				
Transformer	Yes	No	Yes	No
Marking	CE (50 Hz only)		CE (50 Hz only)	
Safety and EMC standard	EN 50178, EN61000-6-2, EN61000-6-4, EN61000-3-11, EN61000-3-12		EN 50178, EN61000-6-2, EN61000-6-4, EN61000-3-11, EN61000-3-12	
Grid standard (check your sales channel for availability)	CEI-0-16, BDEW, RD 661/2007, RD 1565/2010, P.O.12.3		CEI-0-16, BDEW, RD 661/2007, RD 1565/2010, P.O.12.3	

¹⁾ The AC voltage range may vary depending on specific country grid standard

²⁾ The Frequency range may vary depending on specific country grid standard

³⁾ Missing symmetry with respect to ground results in AC disconnection (disabled function by default)

⁴⁾ Power consumption of the auxiliary services not included

Remark. Features not specifically listed in the present data sheet are not included in the product

Deviations according to different levels of AC tension (applicable standard CEI 0-16)			
PVI-55.0-TL-IT	Rated voltage 260 V	Rated voltage 270 V	Rated voltage 280 V
Input side			
MPPT input DC voltage range ($V_{MPPTmin} \dots V_{MPPTmax}$) at V_{acr}	395..950 V Linear derating from max to 31.8% [800< V_{MPPT} <950V]	410..950 V Linear derating from max to 31.8% [800< V_{MPPT} <950V]	485..950 V Linear derating from max to 31.8% [800< V_{MPPT} <950V]
MPPT input DC voltage range ($V_{MPPTmin} \dots V_{MPPTmax}$) at P_{acr} and V_{acr}	395..950 V	410..950 V	425..950 V
Uscita			
Rated AC power (P_{acr})	45 kW	46.7 kW	48.5 kW
Rated grid voltage (V_{acr})	260 V	270 V	280 V
AC voltage range ($V_{ACmin} \dots V_{ACmax}$)	208..299 V ¹⁾	216..310.5 V ¹⁾	224..322 V ¹⁾
Nominal power factor ($\cos\phi_{acr}$)	>0.995 (adj. 0.1 inductive at 0.1 capacitive)	>0.995 (adj. 0.1 inductive at 0.1 capacitive)	>0.995 (adj. 0.1 inductive at 0.1 capacitive)
PVI-55.0-TL-IT	Rated voltage 290 V	Rated voltage 300 V	Rated voltage 310 V
Input side			
MPPT input DC voltage range ($V_{MPPTmin} \dots V_{MPPTmax}$) a V_{acr}	440..950 V Linear derating from max to 31.8% [800< V_{MPPT} <950V]	455..950 V Linear derating from max to 31.8% [800< V_{MPPT} <950V]	470..950 V Linear derating from max to 31.8% [800< V_{MPPT} <950V]
MPPT input DC voltage range ($V_{MPPTmin} \dots V_{MPPTmax}$) at P_{acr} and V_{acr}	440..950V	455..950V	470..950V
Output side			
Rated AC power (P_{acr})	50.2 kW	51.9 kW	53.6 kW
Rated grid voltage (V_{acr})	290 V	300 V	310 V
AC voltage range ($V_{ACmin} \dots V_{ACmax}$)	232..333.5 V ¹⁾	240..345 V ¹⁾	248..356.5 V ¹⁾
Nominal power factor ($\cos\phi_{acr}$)	>0.995 (adj. 0.1 inductive at 0.1 capacitive)	>0.995 (adj. 0.1 inductive at 0.1 capacitive)	>0.995 (adj. 0.1 inductive at 0.1 capacitive)
PVI-110.0-TL-IT	Rated voltage 260 V	Rated voltage 270 V	Rated voltage 280 V
Input side			
MPPT input DC voltage range ($V_{MPPTmin} \dots V_{MPPTmax}$) at V_{acr}	395..950 V Linear derating from max to 31.8% [800< V_{MPPT} <950V]	410..950 V Linear derating from max to 31.8% [800< V_{MPPT} <950V]	425..950 V Linear derating from max to 31.8% [800< V_{MPPT} <950V]
MPPT input DC voltage range ($V_{MPPTmin} \dots V_{MPPTmax}$) at P_{acr} and V_{acr}	395..950V	410..950V	425..950V
Output side			
Rated AC power (P_{acr})	90 kW	93.4 kW	97 kW
Rated grid voltage (V_{acr})	260 V	270 V	280 V
AC voltage range ($V_{ACmin} \dots V_{ACmax}$)	208..299 V ¹⁾	216..310.5 V ¹⁾	224..322 V ¹⁾
Nominal power factor ($\cos\phi_{acr}$)	>0.995 (adj. 0.1 inductive at 0.1 capacitive)	>0.995 (adj. 0.1 inductive at 0.1 capacitive)	>0.995 (adj. 0.1 inductive at 0.1 capacitive)
PVI-110.0-TL-IT	Rated voltage 290 V	Rated voltage 300 V	Rated voltage 310 V
Input side			
MPPT input DC voltage range ($V_{MPPTmin} \dots V_{MPPTmax}$) a V_{acr}	440..950 V Linear derating from max to 31.8% [800< V_{MPPT} <950V]	455..950 V Linear derating from max to 31.8% [800< V_{MPPT} <950V]	470..950 V Linear derating from max to 31.8% [800< V_{MPPT} <950V]
MPPT input DC voltage range ($V_{MPPTmin} \dots V_{MPPTmax}$) a P_{acr} e V_{acr}	440..950V	455..950V	470..950V
Output side			
Rated AC power (P_{acr})	100.4 kW	103.8 kW	107.2 kW
Rated grid voltage (V_{acr})	290 V	300 V	310 V
AC voltage range ($V_{ACmin} \dots V_{ACmax}$)	208..299 V ¹⁾	216..310.5 V ¹⁾	224..322 V ¹⁾
Nominal power factor ($\cos\phi_{acr}$)	>0.995 (adj. 0.1 inductive a 0.1 capacitive)	>0.995 (adj. 0.1 inductive at 0.1 capacitive)	>0.995 (adj. 0.1 inductive at 0.1 capacitive)
PVI-165.0-TL-IT	Rated voltage 260 V	Rated voltage 270 V	Rated voltage 280 V
Input side			
MPPT input DC voltage range ($V_{MPPTmin} \dots V_{MPPTmax}$) a V_{acr}	395..950 V Linear derating from max to 31.8% [800< V_{MPPT} <950V]	410..950 V Linear derating from max to 31.8% [800< V_{MPPT} <950V]	425..950 V Linear derating from max to 31.8% [800< V_{MPPT} <950V]
MPPT input DC voltage range ($V_{MPPTmin} \dots V_{MPPTmax}$) a P_{acr} e V_{acr}	395..950V	410..950V	425..950V
Output side			
Rated AC power (P_{acr})	135 kW	140.1 kW	145.5 kW
Rated grid voltage (V_{acr})	260 V	270 V	280 V
AC voltage range ($V_{ACmin} \dots V_{ACmax}$)	208..299 V ¹⁾	216..310.5 V ¹⁾	224..322 V ¹⁾
Nominal power factor ($\cos\phi_{acr}$)	>0.995 (adj. 0.1 inductive at 0.1 capacitive)	>0.995 (adj. 0.1 inductive at 0.1 capacitive)	>0.995 (adj. 0.1 inductive at 0.1 capacitive)
PVI-165.0-TL-IT	Tensione nominale 290 V	Tensione nominale 300 V	Tensione nominale 310 V
Input side			
MPPT input DC voltage range ($V_{MPPTmin} \dots V_{MPPTmax}$) a V_{acr}	440..950 V Linear derating from max to 31.8% [800< V_{MPPT} <950V]	455..950 V Linear derating from max to 31.8% [800< V_{MPPT} <950V]	470..950 V Linear derating from max to 31.8% [800< V_{MPPT} <950V]
MPPT input DC voltage range ($V_{MPPTmin} \dots V_{MPPTmax}$) a P_{acr} e V_{acr}	440..950V	455..950V	470..950V
Output side			
Rated AC power (P_{acr})	150.6 kW	155.7 kW	160.8 kW
Rated grid voltage (V_{acr})	290 V	300 V	310 V
AC voltage range ($V_{ACmin} \dots V_{ACmax}$)	232..333.5 V ¹⁾	240..345 V ¹⁾	248..356.5 V ¹⁾
Nominal power factor ($\cos\phi_{acr}$)	>0.995 (adj. 0.1 inductive at 0.1 capacitive)	>0.995 (adj. 0.1 inductive at 0.1 capacitive)	>0.995 (adj. 0.1 inductive at 0.1 capacitive)

¹⁾ The output voltage range may vary depending on the standard of connection to the network, valid in the country of installation

Deviations according to different levels of AC tension (applicable standard CEI 0-16)

PVI-220.0-TL-IT	Rated voltage 260 V	Rated voltage 270 V	Rated voltage 280 V
Input side			
MPPT input DC voltage range ($V_{MPPTmin} \dots V_{MPPTmax}$) a V_{acr}	395..950 V Linear derating from max to 31.8% [800<VMPPT<950V]	410..950 V Linear derating from max to 31.8% [800<VMPPT<950V]	485..950 V Linear derating from max to 31.8% [800<VMPPT<950V]
MPPT input DC voltage range ($V_{MPPTmin} \dots V_{MPPTmax}$) a P_{acr} e V_{acr}	395..950 V	410..950 V	425..950 V
Output side			
Rated AC power (P_{acr})	180 kW	186.8 kW	194.0 kW
Rated grid voltage (V_{acr})	260 V	270 V	280 V
AC voltage range ($V_{ACmin} \dots V_{ACmax}$)	208...299 V ¹⁾	216...310.5 V ¹⁾	224...322 V ¹⁾
Nominal power factor ($\cos\phi_{acr}$)	>0.995 (adj. 0.1 inductive at 0.1 capacitive)	>0.995 (adj. 0.1 inductive at 0.1 capacitive)	>0.995 (adj. 0.1 inductive at 0.1 capacitive)

PVI-220.0-TL-IT	Rated voltage 290 V	Rated voltage 300 V	Rated voltage 310 V
Input side			
MPPT input DC voltage range ($V_{MPPTmin} \dots V_{MPPTmax}$) a V_{acr}	440..950 V Linear derating from max to 31.8% [800<VMPPT<950V]	455..950 V Linear derating from max to 31.8% [800<VMPPT<950V]	470..950 V Linear derating from max to 31.8% [800<VMPPT<950V]
MPPT input DC voltage range ($V_{MPPTmin} \dots V_{MPPTmax}$) a P_{acr} e V_{acr}	440..950V	455..950V	470..950V
Output side			
Rated AC power (P_{acr})	200.8 kW	207.6 kW	214.4 kW
Rated grid voltage (V_{acr})	290 V	300 V	310 V
AC voltage range ($V_{ACmin} \dots V_{ACmax}$)	232...333.5 V ¹⁾	240...345 V ¹⁾	248...356.5 V ¹⁾
Nominal power factor ($\cos\phi_{acr}$)	>0.995 (adj. 0.1 inductive at 0.1 capacitive)	>0.995 (adj. 0.1 inductive at 0.1 capacitive)	>0.995 (adj. 0.1 inductive at 0.1 capacitive)

PVI-275.0-TL-IT	Rated voltage 260 V	Rated voltage 270 V	Rated voltage 280 V
Input side			
MPPT input DC voltage range ($V_{MPPTmin} \dots V_{MPPTmax}$) a V_{acr}	395..950 V Linear derating from max to 31.8% [800<VMPPT<950V]	410..950 V Linear derating from max to 31.8% [800<VMPPT<950V]	425..950 V Linear derating from max to 31.8% [800<VMPPT<950V]
MPPT input DC voltage range ($V_{MPPTmin} \dots V_{MPPTmax}$) a P_{acr} e V_{acr}	395..950V	410..950V	425..950V
Output side			
Rated AC power (P_{acr})	225 kW	233.5 kW	242.5 kW
Rated grid voltage (V_{acr})	260 V	270 V	280 V
AC voltage range ($V_{ACmin} \dots V_{ACmax}$)	208...299 V ¹⁾	216...310.5 V ¹⁾	224...322 V ¹⁾
Nominal power factor ($\cos\phi_{acr}$)	>0.995 (adj. 0.1 inductive at 0.1 capacitive)	>0.995 (adj. 0.1 inductive at 0.1 capacitive)	>0.995 (adj. 0.1 inductive at 0.1 capacitive)

PVI-275.0-TL-IT	Rated voltage 290 V	Rated voltage 300 V	Rated voltage 310 V
Input side			
MPPT input DC voltage range ($V_{MPPTmin} \dots V_{MPPTmax}$) a V_{acr}	440..950 V Linear derating from max to 31.8% [800<VMPPT<950V]	455..950 V Linear derating from max to 31.8% [800<VMPPT<950V]	470..950 V Linear derating from max to 31.8% [800<VMPPT<950V]
MPPT input DC voltage range ($V_{MPPTmin} \dots V_{MPPTmax}$) a P_{acr} e V_{acr}	440..950V	455..950V	470..950V
Output side			
Rated AC power (P_{acr})	251 kW	259.5 kW	268 kW
Rated grid voltage (V_{acr})	290 V	300 V	310 V
AC voltage range ($V_{ACmin} \dots V_{ACmax}$)	208...299 V ¹⁾	216...310.5 V ¹⁾	224...322 V ¹⁾
Nominal power factor ($\cos\phi_{acr}$)	>0.995 (adj. 0.1 inductive at 0.1 capacitive)	>0.995 (adj. 0.1 inductive at 0.1 capacitive)	>0.995 (adj. 0.1 inductive at 0.1 capacitive)

PVI-330.0-TL-IT	Rated voltage 260 V	Rated voltage 270 V	Rated voltage 280 V
Input side			
MPPT input DC voltage range ($V_{MPPTmin} \dots V_{MPPTmax}$) a V_{acr}	395..950 V Linear derating from max to 31.8% [800<VMPPT<950V]	410..950 V Linear derating from max to 31.8% [800<VMPPT<950V]	425..950 V Linear derating from max to 31.8% [800<VMPPT<950V]
MPPT input DC voltage range ($V_{MPPTmin} \dots V_{MPPTmax}$) a P_{acr} e V_{acr}	395..950V	410..950V	425..950V
Output side			
Rated AC power (P_{acr})	270 kW	280.2 kW	291 kW
Rated grid voltage (V_{acr})	260 V	270 V	280 V
AC voltage range ($V_{ACmin} \dots V_{ACmax}$)	208...299 V ¹⁾	216...310.5 V ¹⁾	224...322 V ¹⁾
Nominal power factor ($\cos\phi_{acr}$)	>0.995 (adj. 0.1 inductive at 0.1 capacitive)	>0.995 (adj. 0.1 inductive at 0.1 capacitive)	>0.995 (adj. 0.1 inductive at 0.1 capacitive)

PVI-330.0-TL-IT	Rated voltage 290 V	Rated voltage 300 V	Rated voltage 310 V
Input side			
MPPT input DC voltage range ($V_{MPPTmin} \dots V_{MPPTmax}$) a V_{acr}	440..950 V Linear derating from max to 31.8% [800<VMPPT<950V]	455..950 V Linear derating from max to 31.8% [800<VMPPT<950V]	470..950 V Linear derating from max to 31.8% [800<VMPPT<950V]
MPPT input DC voltage range ($V_{MPPTmin} \dots V_{MPPTmax}$) a P_{acr} e V_{acr}	440..950V	455..950V	470..950V
Output side			
Rated AC power (P_{acr})	301.2 kW	311.4 kW	321.6 kW
Rated grid voltage (V_{acr})	290 V	300 V	310 V
AC voltage range ($V_{ACmin} \dots V_{ACmax}$)	232...333.5 V ¹⁾	240...345 V ¹⁾	248...356.5 V ¹⁾
Nominal power factor ($\cos\phi_{acr}$)	>0.995 (adj. 0.1 inductive at 0.1 capacitive)	>0.995 (adj. 0.1 inductive at 0.1 capacitive)	>0.995 (adj. 0.1 inductive at 0.1 capacitive)

¹⁾ The AC voltage range may vary depending on specific country grid standard

Efficiency curves PVI-55.0/330.0-TL

Efficiency curves PVI-275.0/330.0

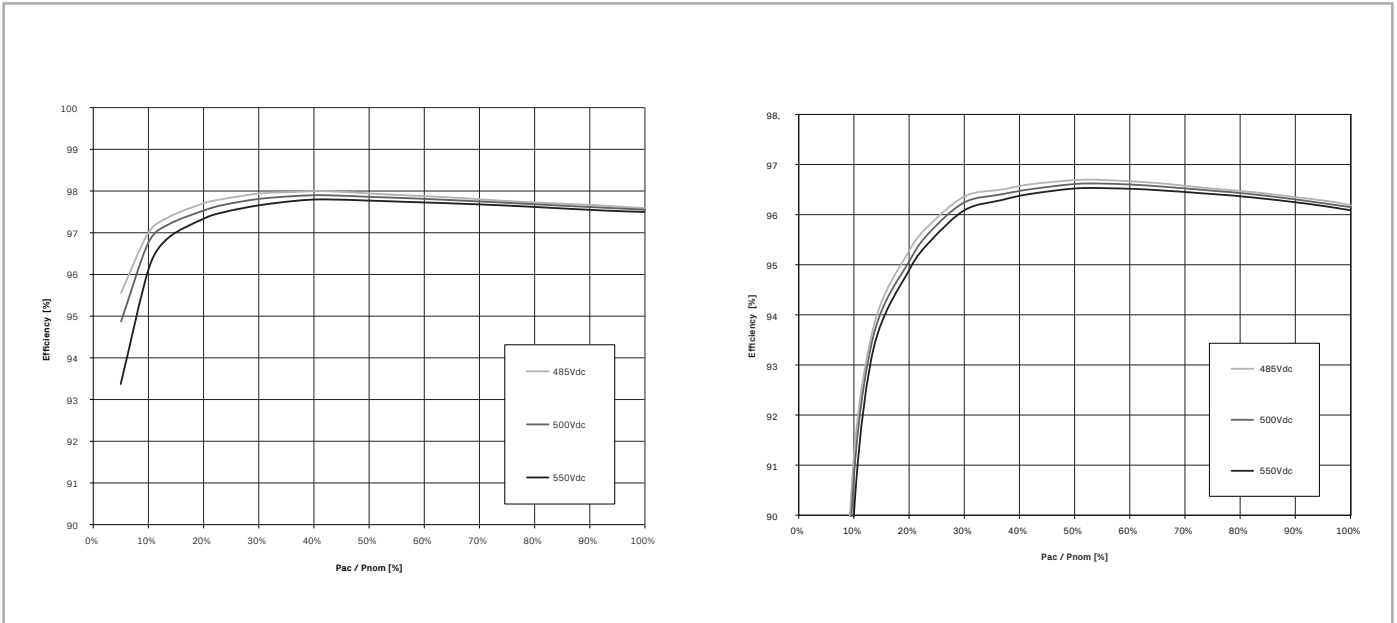

For more information please contact your local FIMER representative or visit:

fimer.com

We reserve the right to make technical changes or modify the contents of this document without prior notice. With regard to purchase orders, the agreed particulars shall prevail. FIMER does not accept any responsibility whatsoever for potential errors or possible lack of information in this document.

We reserve all rights in this document and in the subject matter and illustrations contained therein. Any reproduction, disclosure to third parties or utilization of its contents – in whole or in parts – is forbidden without prior written consent of FIMER. Copyright© 2021 FIMER. All rights reserved.

