

FIMER



Solar Inverter

PowerUNO

FIM-HY-2.0 to 6.0-SE-A-1PH

Quick Installation Guide



EN: Operative manual
IT: Manuale operativo
DE: Bedienungsanleitung
SP: Operación manual
PR: manual de operações

**APPLY HERE
THE COMMUNICATION
IDENTIFICATION LABEL**

In addition to what is explained in this quick installation guide, the safety and installation information provided in the product manual must be read and followed. The technical documentation for the product is available at the website.
The device must be used in the manner described in the manual. If this is not the case the safety devices guaranteed by the inverter might be ineffective.

List of supplied components

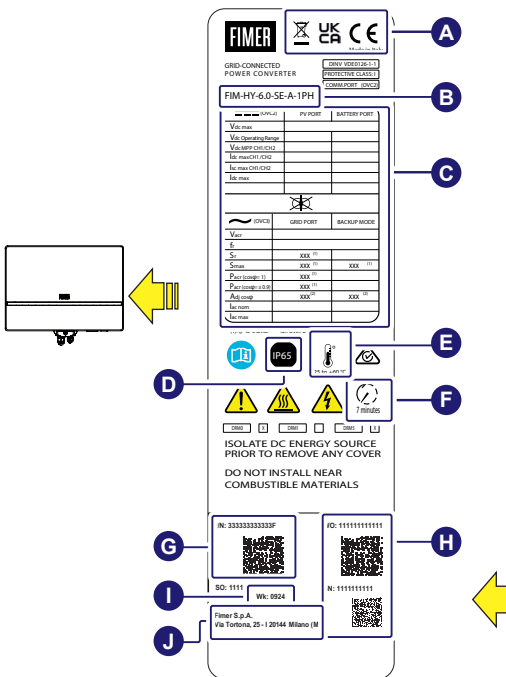
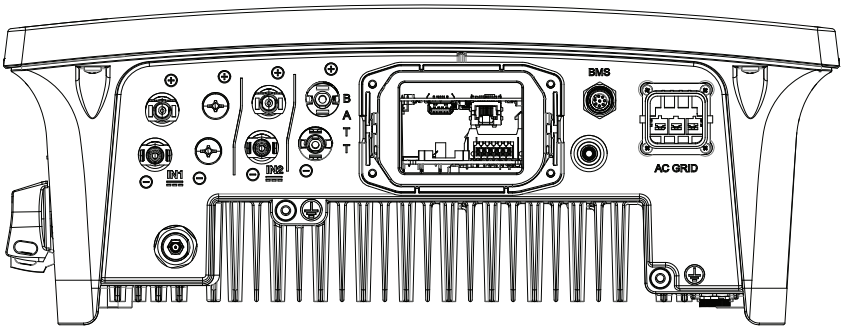
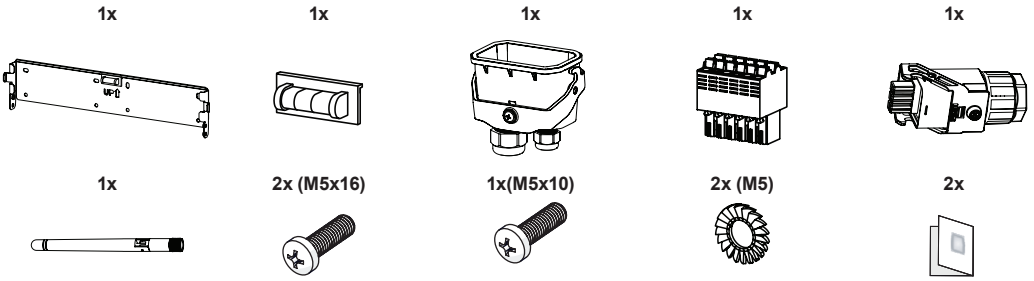

- A Certification marks
- B Inverter model
- C Main technical data
- D Environmental protection rating
- E Degrees of protection provided by enclosures (IP Code)
- F Discharge time
- G Inverter Part Number
- Serial Number (YYWWSSSSSS)
- H - Inverter access point SSID: FIMER-YYWWSSSSSS
- "Host Name": http://FIMER-YYWWSSSSSS.local
- It is required to register the inverter in Aurora Vision.
- I Production date: WWYY where: WW (week) YY (year)
- J Manufacturer
- L WLAN (Wi-Fi) and ETH1 (Ethernet) MAC addresses
- M Inverter Serial Number (YYWWSSSSSS)
- N Product Key
- O QR Code:
To be used to commission inverter using FIMER internal WebUI

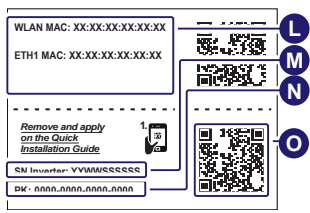

1. Mounting location

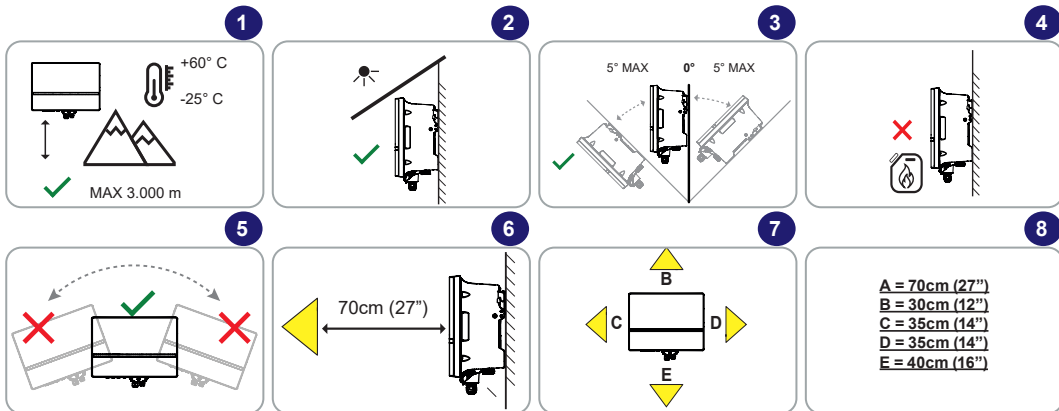

Environmental

Ambient temperature range	-25...+60°C
Relative humidity	4...100 % condensing
Acoustic noise emission level	< 40 dBA @ 1 m
Acoustic noise emission level (worst case)	< 50 dBA @ 1 m
Maximum operating altitude	3000 m (9842 ft) with derating above 2000 m (6561 ft)

Physical

Environmental protection rating	IP65
Cooling	Natural
Dimension (HxWxD)	330 mm x 460 mm x 160 mm
Weight	14.5 kg
Mounting system	Wall bracket

2. Mounting Instruction

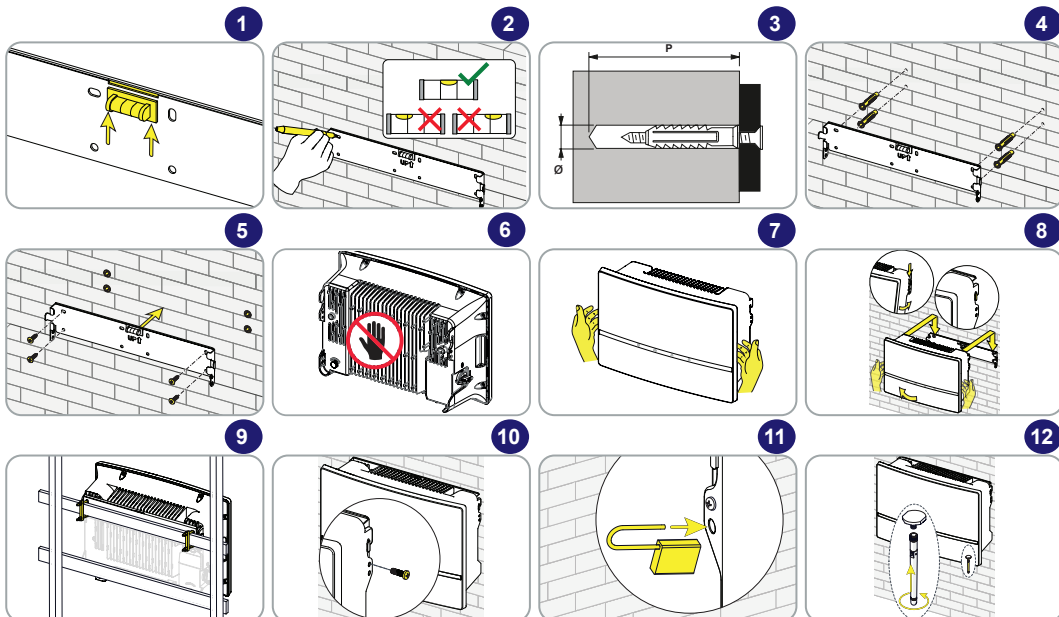

3. Protective earthing (PE)

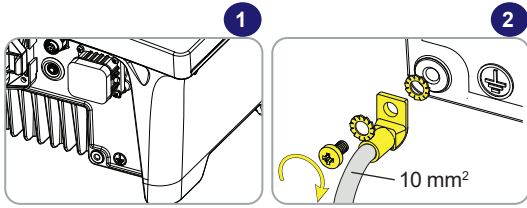

4. DC inputs

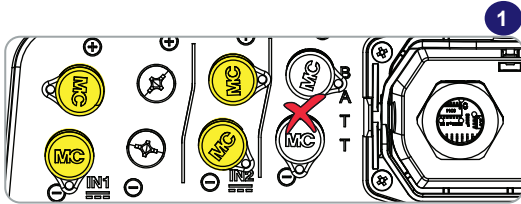

	IN1	IN2
FIM-HY-2.0-SE-A-1PH	16 A	-
FIM-HY-3.0 to 6.0-SE-A-1PH	16 A	16 A

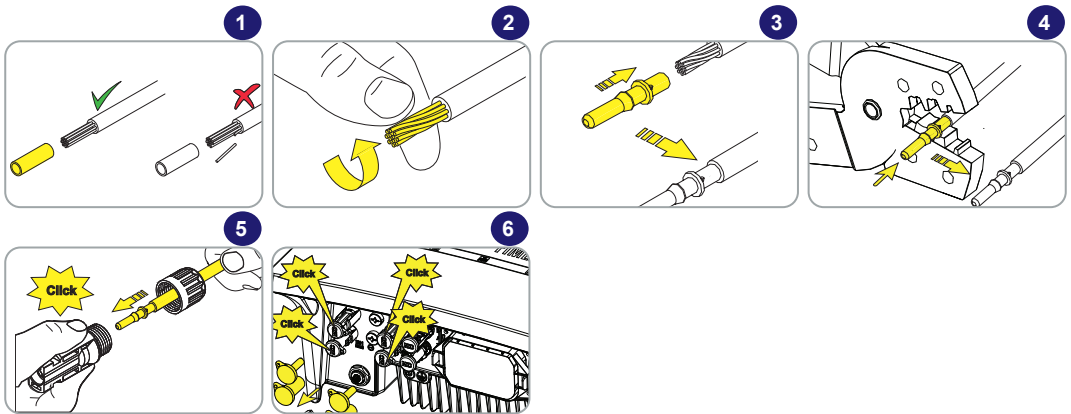

5. Battery PowerX connection (optional PowerX wiring kit needed)

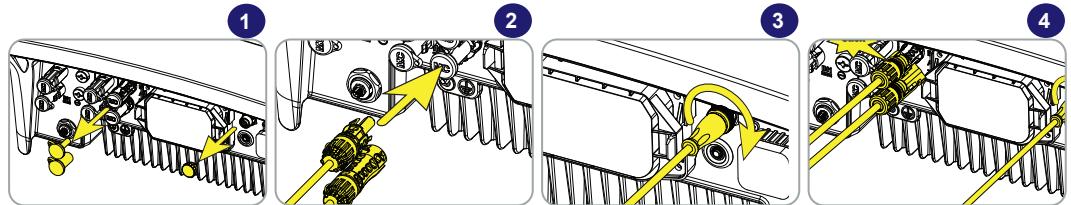

6. Line cable and protection device

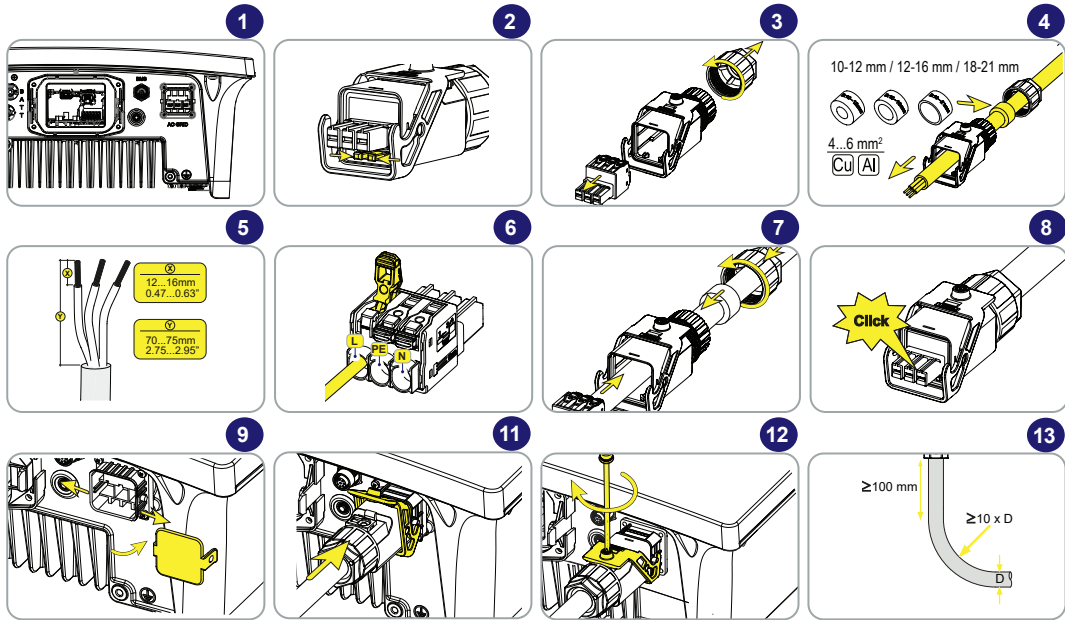

Load protection breaker

Type	Automatic circuit breaker with thermal magnetic protection
Voltage/Current rating	FIM-HY-2.0 - 230Vac min. 16A FIM-HY-3.0 - 230Vac min. 16A FIM-HY-3.3 - 230Vac min. 20A FIM-HY-3.6 - 230Vac min. 20A FIM-HY-4.0 - 230Vac min. 25A FIM-HY-4.6 - 230Vac min. 25A FIM-HY-5.0 - 230Vac min. 25A FIM-HY-6.0 - 230Vac min. 32A
Magnetic protection characteristic	Magnetic curve B/C
Number of poles	2W (I+N)

Residual current protection device requirements

All PowerUNO models

Type	A / AC
Sensitivity	300mA

Inverter model	Line conductor maximum length (m)	
	4mm ²	6mm ²
FIM-HY-2.0	31	47
FIM-HY-3.0	21	31
FIM-HY-3.3	19	29
FIM-HY-3.6	17	26
FIM-HY-4.0	16	24
FIM-HY-4.6	14	21
FIM-HY-5.0	13	19
FIM-HY-6.0	10	16

7. AC On-Grid connection

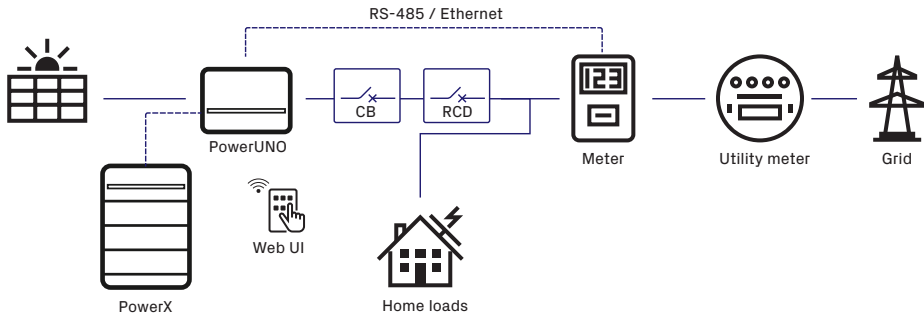

8. AC On-Grid connection with backup functionality

(optional PowerBox needed)

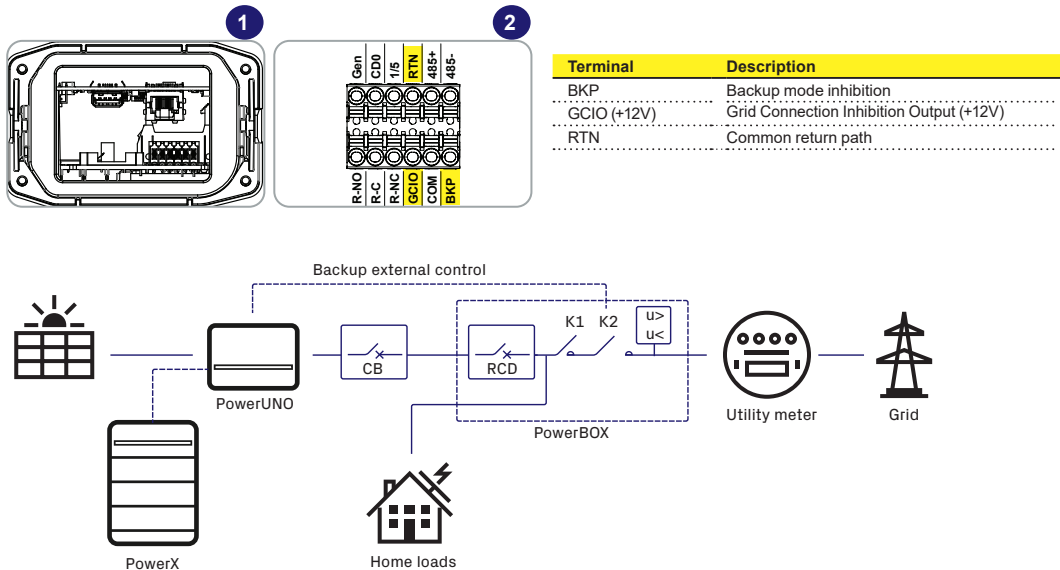

9. Off-Grid Stand Alone

(PowerBox not needed)

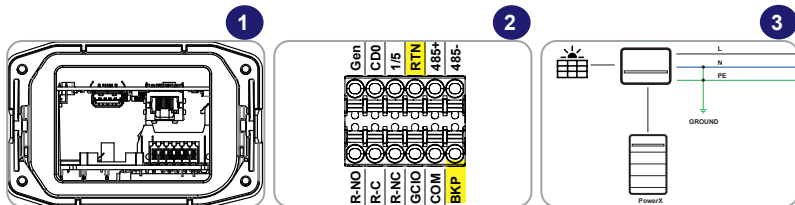

Terminal	Description
BKP	Backup mode inhibition
RTN	Common return path

NOTE – Shorting BKP and RTN produces the stand-alone voltage.

10. Wi-Fi / AFCI button

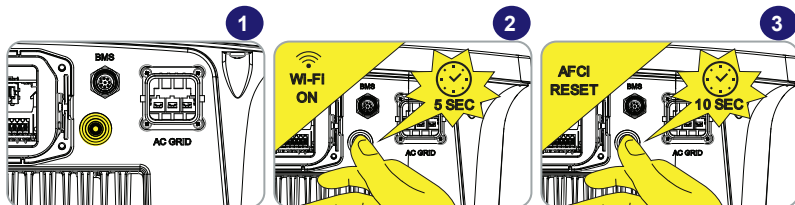

11. Ethernet

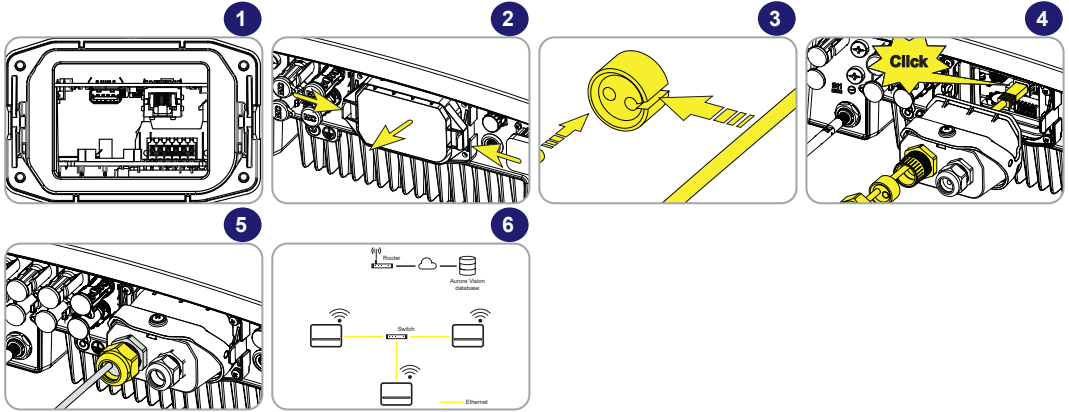

Embedded communication	
Embedded physical interface	Wi-Fi, Ethernet, RS-485
Embedded communication protocols	Modbus TCP (SunSpec)
Datalogger data retention	30 days
Remote monitoring	Energy Viewer (mobile APP), Energy Viewer Web, Plant Portfolio Manager
Local monitoring	Energy Viewer (mobile APP)

12. DRM, Remote OFF, RS-485, Load Manager relay

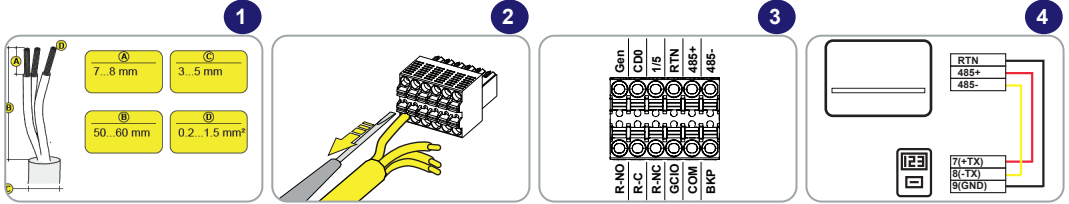

13. Commissioning



14. Characteristics and technical data

Inverter	FIM-HY-2.0	FIM-HY-3.0	FIM-HY-3.3	FIM-HY-3.6	FIM-HY-4.0	FIM-HY-4.6	FIM-HY-5.0	FIM-HY-6.0
AC								
Absolute maximum DC voltage (V _{max,abs})	600 V							
Start-up DC voltage (V _{start})	150 V	150 V	150 V	150 V	200 V	200 V	200 V	200 V
Rated DC voltage (V _{dcr})	390 V							
Rated DC power (P _{dcr})	2051 W	3077 W	3385 W	3692 W	4103 W	4718 W	5128 W	6154 W
Suggested maximum DC power DC/AC ratio	3000 W	4500 W	4950 W	5400 W	6000 W	7040 W	7500 W	9000 W
Number of independent MPPT	1	2	2	2	2	2	2	2
Max DC power for each MPPT (P _{MPPTmax})	3060 W	2300 W	2520 W	2755 W	3060 W	3520 W	3820 W	4592 W
DC voltage range of MPPT (V _{MPPTmin} ... V _{MPPTmax}) at P _{acr}	135...500V	135...500 V	135...500 V	145...500 V	165...500 V	170...500 V	180...500 V	200...500 V
Max DC current	16 A				32 A / 16 A - 16 A			
Max short circuit current per MPPT	MPPT1				MPPT1-MPPT2			
Grid connected output side								
AC Grid connection type	Single-phase							
Rated AC power (P _{acr @cosφ=1})	2000 W	3000 W	3300 W	3600 W	4000 W	4600 W	5000 W	6000 W
Rated AC grid voltage (V _{ac,r})	220 / 230 / 240 V							
AC voltage range ²⁾	180...264 V							
Rated Output Current at Vac 230V (I _{ac,r})	8.7 A	13.0 A	14.4 A	15.7 A	17.4 A	20.0 A	21.7 A	26.1 A
Maximum AC current (I _{ac,max})	10.0 A	14.5 A	16.0 A	16.0 A	19.5 A	22.3 A	22.8 A	27.3 A
Rated frequency (fr)	50 Hz / 60 Hz							
Battery input/output								
Max operating current	17 A							
Maximum charge power	3060 W	4600 W	5040 W	5510 W	6120 W	7040 W	7040 W	7040 W
Maximum discharge power	2000 W	3000 W	3300 W	3600 W	4000 W	4600 W	5000 W	6000 W

2) Refer to the document "String inverter – Product Manual appendix" available at www.fimer.com/solarinverters to know the brand and the model of the quick fit connector

For complete data refer to the technical data sheet on www.fimer.com



For more information please contact your local FIMER representative or visit:

fimer.com

We reserve the right to make technical changes or modify the contents of this document without prior notice. With regard to purchase orders, the agreed particulars shall prevail. FIMER does not accept any responsibility whatsoever for potential errors or possible lack of information in this document.

We reserve all rights in this document and in the subject matter and illustrations contained therein. Any reproduction, disclosure to third parties or utilization of its contents – in whole or in parts – is forbidden without prior written consent of FIMER. Copyright© 2024 FIMER. All rights reserved.