

ABB compact skid

PVS980-CS – up to 5000 kVA



01

01 ABB compact skid, PVS980-CS, with PVS980-58 central inverter, MV transformer and MV switchgear

Turnkey-solution for PV power plants

The ABB compact skid design capitalizes on ABB's long experience in developing and manufacturing secondary substations for utilities and major end users worldwide in conventional power transmission installations.

A skid houses one 1500 V_{DC} 4348 to 5000kVA ABB PVS980-58 central inverter, an optimized MV oil immersed transformer, MV switchgear and all needed auxiliary services. The ABB compact skid is used to connect a PV power plant to a MV electricity grid easily and rapidly. To meet the PV power plant's demanded capacity, several ABB compact skids can be used.

Compact design eases transportation

The compact skid solution has dimensions suitable for transportation inside closed 40 feet High Cube (HC) shipping container. The total package weighs less than 24 tons. The standardized shipping dimensions ensures cost-effective and safe transportability to the site, even overseas. Inverter's optimized air circulation and filtering

The ABB compact skid is a plug and play solution designed for large-scale solar power generation using PVS980-58 high-power central inverters. It houses all the electrical equipment that is needed to rapidly connect a photovoltaic (PV) power plant to a medium voltage (MV) electricity grid.

system, together with hermetically sealed oil immersed transformer enable installations in various ambient conditions, from harsh desert temperatures to cold and humid environments. The ABB compact skid is designed for at least 25 years of operation.

Highlights

- Proven technology and reliable components
- Compact and robust design
- Outstanding endurance for outdoor use
- High DC input voltage up to 1500 V_{DC}
- High total efficiency
- Extensive DC and AC side protection
- Self-contained cooling system for inverters
- Modular and serviceable system
- Embedded auxiliary power distribution system
- Extendable manufacturing footprint with fast deliveries
- Global life cycle services and support
- Transportable inside closed 40 feet HC shipping container
- Arc-proof design

PVS980-CS

Solar inverters

The ABB PVS980-58 inverter has been developed on the basis of over 50 years of experience in the power electronics industry and proven technology platform. Unrivalled expertise from the world's market and technology leader in frequency converters is the hallmark of this solar inverter series. The PVS980-58 inverter is one of the most efficient and cost-effective ways of converting the direct current (DC) generated by solar modules into high quality and CO₂-free alternating current (AC) that can be fed into the power distribution network. One ABB central inverter is used in the ABB compact skid. The inverter provides high conversion efficiency with low auxiliary power consumption, as well as very low maintenance need.

Transformer

The ABB compact skid includes an oil immersed transformer. The transformer is designed to meet the reliability, durability and efficiency required in PV applications. It is specifically designed and

optimized for the PVS980-58 inverter to provide the best performance throughout the lifetime of the plant.

As a major global transformer manufacturer, ABB offers a wide range of transformers. Different power transformers are available to meet customer requirements. All ABB's transformers are manufactured in accordance with the most demanding industry and international standards.

Switchgear

The ABB compact skid is equipped, as standard, with the widely proven ABB SafeRing, SF₆-insulated switchgear. A sealed steel tank with constant atmospheric conditions ensures a high level of reliability as well as personnel safety. The virtually maintenance-free system comes in a compact and flexible design that allows for a versatile switchgear configuration with arc-proof capability.

Technical data and types

Type code	4.3MVA	4.6MVA	4.8MVA	5.0MVA
Maximum rating in kVA	4348	4565	4782	5000
Inverter				
Inverter	PVS980-58, 4.3-5MVA			
Maximum operating DC input voltage	1500 V			
Number of inverters	1	1	1	1
Number of independent mppt	1	1	1	1
mppt range @ 35° C in V	850-1500	893-1500	935-1500	978-1500
mppt range @ 50° C in V	850-1100	893-1100	935-1100	978-1100
AC output voltage	600 V	630 V	660 V	690 V
MV transformer				
Transformer type	Oil immersed (ONAN)			
AC Power @ 25° C in kVA	4343	4565	4782	5000
AC Power @ 35° C in kVA	4229	4441	4652	4864
AC Power @ 50° C in kVA	3845	4037	4229	4421
Number of secondary windings	1	1	1	1
Low voltage level	600 V	630 V	660 V	690 V
Medium voltage level range	≤ 36 kV			
Rated frequency	50Hz or 60 Hz			
Oil type	Mineral (vegetable optional)			
Tap changer	± 2 x 2.5%			
Winding material (primary / secondary)	Al / Al			
Eco efficiency optional	Yes			
MV switchgear				
Switchgear type	SF6-insulated			
Rated current	630 A			

ABB compact skid design and grid connection

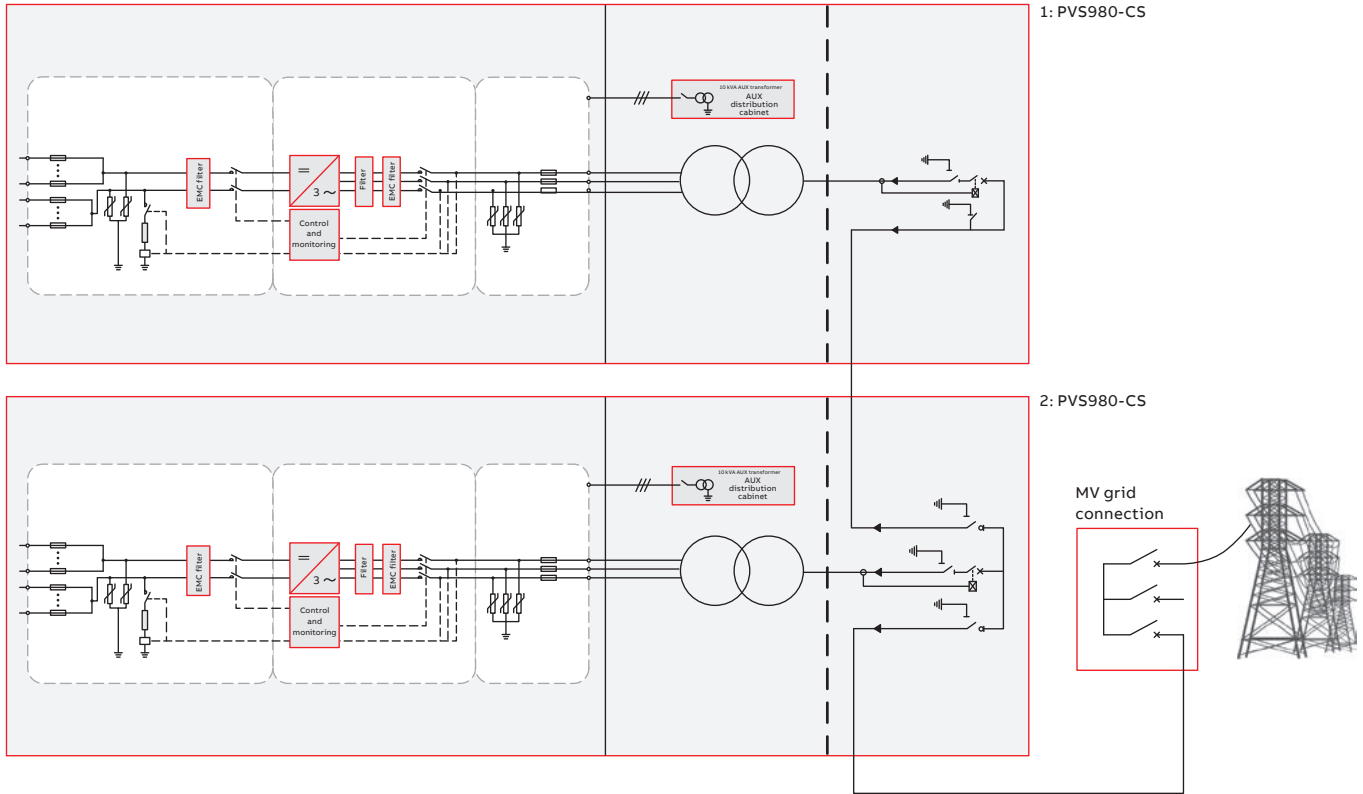

Technical data and types

Type code	4.3MVA	4.6MVA	4.8MVA	5.0MVA
Configuration	Single (CV) or double feeder (CCV)			
Protection (up to 24 kV / up to 36 kV)	Circuit breaker (16 kA or 20 kA / 20 kA or 25 kA)			
Protection relay type	REJ603 (others on request)			
Motorized optional	Yes			
Auxiliary supply				
Auxiliary transformer power	10 kVA (higher on request)			
Auxiliary transformer primary voltage level	600 V	630 V	660 V	690 V
Auxiliary transformer secondary voltage level	400-230 V			
Low voltage distribution panel for auxiliary functions	Yes			
Mechanical characteristics				
Transport dimensions (length x width x height) in mm	11850 x 2150 x 2570 (40ft HC container dimensions)			
Weight approx. in ton	24			
Environmental				
Operating temperature range	-20° C ... +50° C			
Operating altitude range	≤ 2000 m			
Relative humidity (non-condensing)	≤ 95%			
Environmental protection rating	IP 54 (IP 55 for inverter)			
Painting corrosion protection	C4 (C5M optional)			
Product compliance				
Conformity	IEC 60364, IEC 61936-1, IEC 60502-1			
Grid support	Reactive power compensation (also at night), power reduction, LVRT, HVRT, FqRT			



02

02 ABB compact skid, PVS980-CS – a compact plug and play solution transportable inside a 40 feet High Cube container.

MV switchgear standard configurations for ABB compact skid

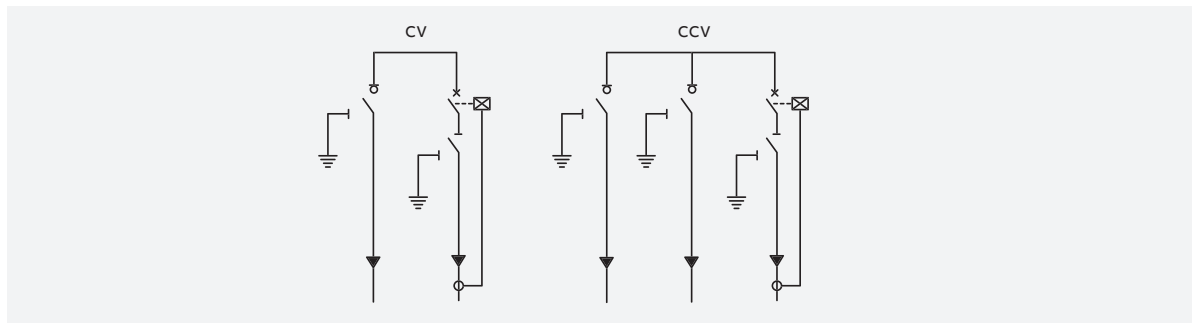

Accessories

- Solar array junction boxes with string monitoring
- Remote monitoring solutions

Options

- MV AC output voltages up to 36 kV
- Different MV switchgear configurations
- I/O extensions
- Floating DC
- Fieldbus and Ethernet connections
- Auxiliary power supply up to 40kVA
- C5M enclosure corrosion protection (inverter C4)
- Warranty extensions
- LV AC breaker to inverter output

Support and service

ABB supports its customers with a dedicated service network in more than 60 countries and provides a complete range of life cycle services from installation and commissioning to preventative maintenance, spare parts, repairs and recycling.

For more information please contact your local ABB representative or visit:

www.abb.com/solarinverters
www.abb.com

We reserve the right to make technical changes or modify the contents of this document without prior notice. With regard to purchase orders, the agreed particulars shall prevail. ABB does not accept any responsibility whatsoever for potential errors or possible lack of information in this document.

We reserve all rights in this document and in the subject matter and illustrations contained therein. Any reproduction, disclosure to third parties or utilization of its contents – in whole or in parts – is forbidden without prior written consent of ABB. Copyright© 2020 ABB All rights reserved

